



# WavePro LT

## Busway System



GE imagination at work

# Features of Busway System

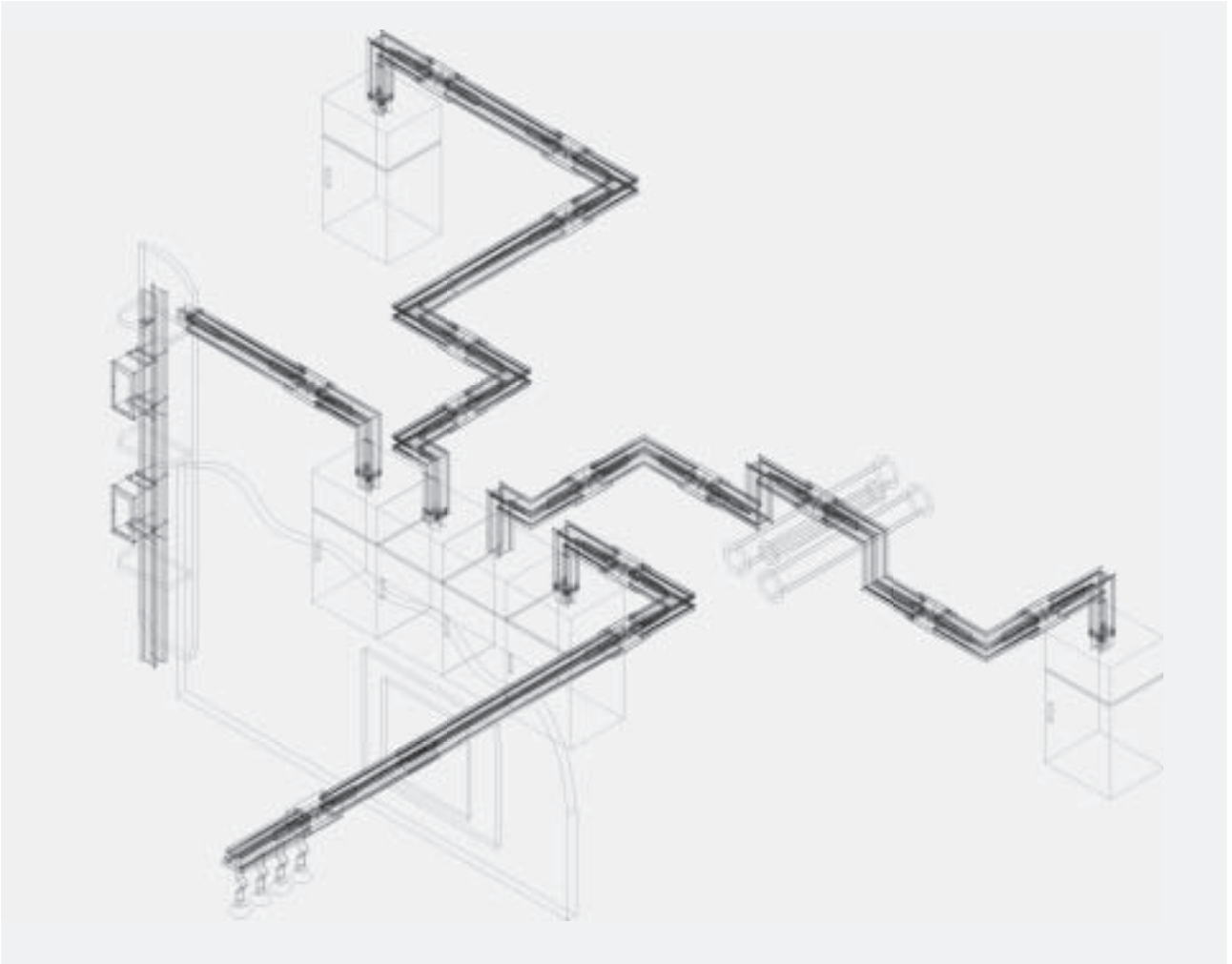

## Safe structure of bus plug

- The **operating handle of the plug** can be installed on the top or side with accurate opening or closing indication.
- The **padlock mechanism** is set for protecting the plug from maloperation and any unauthorised access.
- Fuse plug is provided with **special removable tools**.
- **Plug outlet covers** are used to prevent unintentional contact of the busbar.
- **Plug-in units are automatically grounded** on installation. Polarised engagement of the plug to the busway provides the installer with positive plug/phase alignment.
- **The plug is provided** with internal interlocking mechanism to prevent the plug door being opened whilst energised, ensuring operation safety.



## Smaller size and higher flexibility

- The **compact "sandwich" design** saves space with minimum voltage drop. All function units can fit into any angle and height of architectural space such as between floors or along walls.
- The conductor is fully enclosed within the aluminium housing, which provides excellent heat dissipation, thus improving the power transmission efficiency and low voltage drop.

## Aluminum alloy housing

- With light-weight, **aluminum alloy housing**, the unique design can fit your specific application with high flexibility, safety and reliability.
- The powder **coated aluminum alloy housing** has been tested to withstand the salt spray test.
- The **aluminum alloy housing is corrosion resistant**, has high heat dissipation and provides an extremely low impedance ground path. The entire housing has 50% grounding capacity.

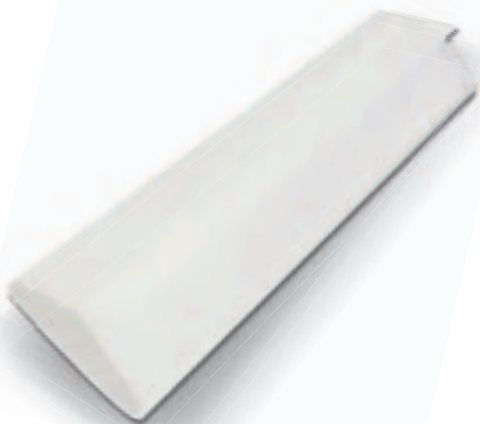
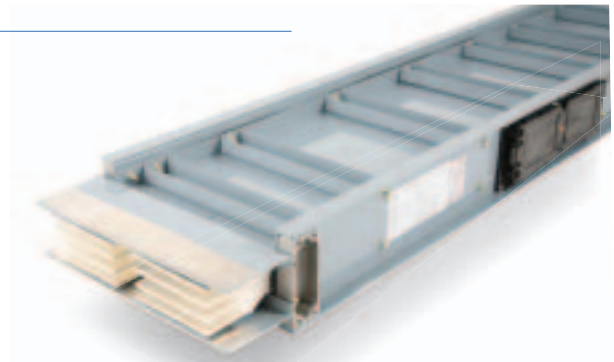

## High performance conductive and insulating material

- Busway system utilises high performance tin-plated copper or silverplated aluminium conductor, and provides 100% protection from corrosion and high conductivity at the contact surface.
- The conductive busbar is wholly wrapped in B Class (130°C) insulating material, providing significant insulation level and resistance to impact.
- The insulating material used meets the requirements of ROHS.

## Quick and easy connection

- The **joint assembly** consists of a cone-shaped insulation plate to increase mechanical strength while the moulded joint ground side plate ensures even pressure applied across the joint.
- **Large sized Belleville washers** assure even pressure on contact.
- A **common 16mm** socket wrench is used to fasten the fixed torque bolt with red indication disc. (When the indicating disc falls off, the joint is tightened properly without using torque wrench).
- Field **adjustable isolation** joint allows for 16mm per joint providing flexibility on the installation.

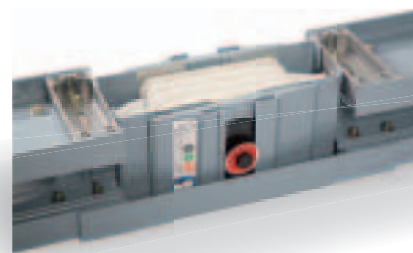

# Advantages compared to Cable

- Busway is **quick and easy to install**. Using busway can save up to 30% of the cost of using cable as it takes approximately half the time to install.
- **High overload capacity**: All insulation materials used in busway is Class B (130°C) while cable is generally rated at 95°C and 105°C. Therefore, the overload capacity of the busway is much higher than that of cables.
- WavePro LT has **good heat dissipation performance**: Insulating layers of cables (core insulation and outer insulation) are insulating electrically as well as thermally, while the busway disperses heat through air conduction and radiates heat through the tightly contacted housing. Busway has superior heat dissipation performance than cable.

2000A, 3P4W

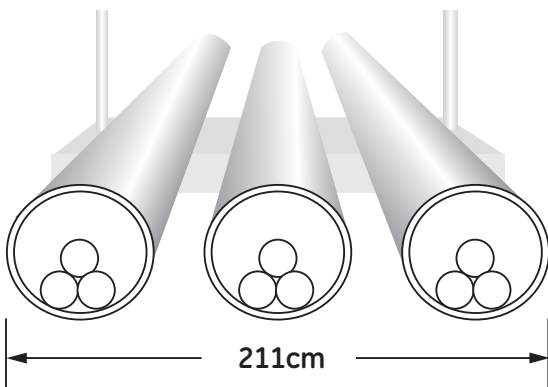
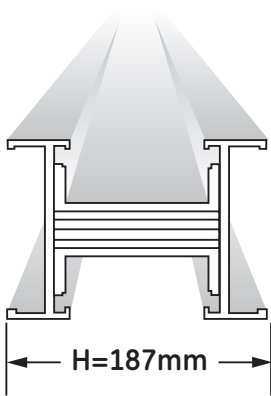

## Weight

weight: (kg/m)

Rated current (A)	Copper busbar (H)	Aluminium busbar (H)	Aluminium busbar 4W	Aluminium busbar 5W
100	~	~	6.7	7.0
160	~	~	6.7	7.0
200	~	~	6.7	7.0
250	9	9.5	6.7	7.0
400	11.5	12.3	7.7	8.1
500	~	~	8.3	8.7
630	12.5	13.4	9	9.5
800	15	16.2	10.7	11.3
1000	17.4	19	11.5	12.2
1250	21.2	23.1	14.2	15.2
1350	22.3	24.5	15	16.2
1600	26.9	29.6	16.9	18.3
2000	34.1	38.4	20.1	21.7
2500	51.8	58.3	24.5	26.6
3150	62.6	69.3	33.6	36.7
3800	74.5	82.5	40.7	44.5
4000	79.3	87.9	44	48.1
4500	99.9	110.8	~	~
5000	109.6	121.6	~	~

## Dimension

Size: mm

Rated current (A)	Copper busbar (H)	Aluminium busbar (H)
100	~	87
160	~	87
200	~	87
250	77	87
400	87	97
500	~	107
630	92	117
800	102	137
1000	131	152
1250	151	182
1350	158	197
1600	183	217
2000	233	257
2500	262	307
3150	339	459
3800	389	549
4000	409	589
4500	499	~
5000	539	~

# Electrical Characteristics

WavePro LT Series busway's all-aluminum and aluminum alloy housing provides an extremely low impedance ground path with small resistance (good continuous current capacity) for both copper and aluminum systems.

Plug-in outlet grounding is supplied with tin-plated copper tabs bolted to the plug in box housing for superior

continuity through standard bus plug ground stabs. Internal ground bus bar (50% or 100% capacity ) is also available to provide a complete system.

## Grounding bar resistance of WavePro LT busway system (Temperature=20°C):

### DC resistance Copper bar (Internal 50% ground bus)

No.	Rated current (A)	Resistance (10 <sup>-6</sup> Ω/m)
1	250	308.8
2	400	207.9
3	630	179.1
4	800	141.1
5	1000	88.8
6	1250	70.9
7	1350	68.8
8	1600	56.5
9	2000	44.0
10	2300	45.8
11	2500	37.6
12	3150	28.9
13	3800	24.8
14	4000	23.3
15	4500	18.8
16	5000	17.4

### DC resistance Copper bar (Internal 50% ground bus + Integrated housing ground)

No.	Rated current (A)	Resistance (10 <sup>-6</sup> Ω/m)
1	250	154.4
2	400	104.0
3	630	89.6
4	800	70.5
5	1000	44.4
6	1250	35.5
7	1350	34.4
8	1600	28.3
9	2000	22.0
10	2300	22.9
11	2500	18.8
12	3150	14.4
13	3800	12.4
14	4000	11.7
15	4500	9.4
16	5000	8.7

### DC resistance Aluminium bar (Internal 50% ground bus)

No.	Rated current (A)	Resistance (10 <sup>-6</sup> Ω/m)
1	100	342.7
2	160	342.7
3	200	342.7
4	250	342.7
5	400	259.8
6	500	210.7
7	630	178.1
8	800	138.0
9	1000	119.4
10	1250	95.2
11	1350	86.1
12	1600	76.9
13	2000	63.3
14	2300	56.4
15	2500	52.7
16	3150	35.0
17	3800	28.6
18	4000	25.2

### DC resistance Aluminium bar (Internal 50% ground bus + Integrated housing ground)

No.	Rated current (A)	Resistance (10 <sup>-6</sup> Ω/m)
1	100	171.3
2	160	171.3
3	200	171.3
4	250	171.3
5	400	129.9
6	500	105.3
7	630	89.0
8	800	69.0
9	1000	59.7
10	1250	47.6
11	1350	43.0
12	1600	38.5
13	2000	31.7
14	2300	28.2
15	2500	26.3
16	3150	17.5
17	3800	14.3
18	4000	12.6

Note:

$$R = \rho_{20} [1 + \alpha(T - 20)] \cdot K_j \cdot K_i \cdot L / (b \cdot h) \cdot 10^{-6} \text{ (}\Omega/\text{m)}$$

$\rho_{20}$ : resistivity of 20°C resistivity of Cu is 0.0179Ω.mm<sup>2</sup>/m, and resistivity of Al is 0.0295Ω.mm<sup>2</sup>/m

$\alpha$ : temperature coefficient of resistance, temperature coefficient of resistance of Cu is 0.00385°C<sup>-1</sup>, temperature coefficient of resistance of Al is 0.00403°C<sup>-1</sup>

T: ambient temperature (°C)

K<sub>j</sub>: coefficient of skin effect, select appropriate rate according to b\*h

K<sub>i</sub>: coefficient of proximity effect, select 1.03

L: conductor length (m)

b: conductor width (mm)

h: conductor thickness (mm)

For instance:

To get the restistance data of 90 C,

$$R = \rho_{20} [1 + \alpha(90 - 20)] \cdot K_j \cdot K_i \cdot L / (b \cdot h) \cdot 10^{-6} \text{ (}\Omega/\text{m)}$$



## Electrical Characteristics

### Short-circuit current ratings

The WavePro LT busway design provides predictable, consistent strength and high short-circuit ratings.

WavePro busway is third party certified by KEMA to be in compliance with IEC60439-1 and-2 short circuit withstand test for 1 second.

#### Copper conductor

Rated current (A)	Rated short-time withstand current (kA)	Rated peak withstand current (kA)
250-800	30	63
1000-1600	50	105
2000-2500	65	143
3150-5000	100	220

lcw@1s

#### Aluminium conductor

Rated current (A)	Rated short-time withstand current (kA)	Rated peak withstand current (kA)
100-250	10	17
400-500	20	40
630-800	30	63
1000-2500	50	105
3150-4000	80	176

lcw@1s

### Ambient temperature's influence on application

Within the ambient temperature of 40°C, WavePro LT busway system can continuously operate at rated current while the maximum housing temperature rise won't exceed 55 K.

If the busway is intended to be continually operated at higher ambient temperature, it should be derated first, i.e. the busway current carrying capacity = rated current x de-rating factor. (As shown in tables)

Ambient temperature (°C)	Factor
40	1.00
45	0.95
50	0.90
55	0.85
60	0.80
65	0.74
70	0.67

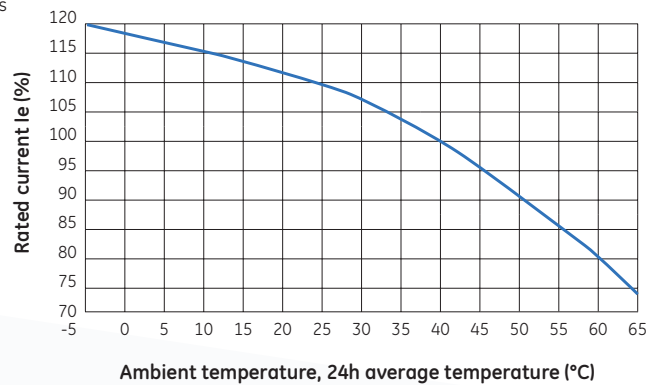

# Electrical Characteristics

## Resistance, reactance, impedance and voltage drop

WavePro LT busway has low voltage-drop values. Minimum reactance (X) is due to very close bar spacings (sandwiched construction) and a non-magnetic housing. Values shown are identical for plug-in and feeder.

50 Hz values shown. For 60 Hz, multiply reactance (X) by 1.2048 and resistance values do not change. For 400 Hz, multiply reactance by 4.6988 and multiply resistance by 1.4. Calculate new voltage drop  $V_d = \text{amps load} \times \sqrt{3} (R \cos\phi + X \sin\phi) \text{ m}$ , where  $\cos\phi = \text{Power Factor}$ .

Contact your local GE representative for help with electrical calculations.

### Copper busbar (50 Hz, temperature=20°C)

Rated current (A)	Resistance	Reactance (10 <sup>-6</sup> Ω/m)	Impedance	Voltage drop (V/m)				
				Power factor cosφ				
				0.6	0.7	0.8	0.9	1.0
250	154.4	44.8	160.8	0.056	0.061	0.065	0.069	0.067
400	104.0	35.3	109.8	0.063	0.068	0.072	0.076	0.072
630	89.6	32.1	95.1	0.087	0.093	0.099	0.103	0.098
800	70.5	27.4	75.7	0.089	0.095	0.101	0.105	0.098
1000	56.8	18.1	59.6	0.084	0.091	0.098	0.102	0.098
1250	46.3	15.6	48.8	0.087	0.094	0.100	0.105	0.100
1350	43.4	14.9	45.9	0.089	0.096	0.102	0.107	0.101
1600	36.1	13	38.4	0.089	0.096	0.102	0.106	0.100
2000	28.6	11	30.7	0.090	0.097	0.102	0.106	0.099
2300	22.9	12.3	26.0	0.094	0.099	0.102	0.104	0.091
2500	18.8	10.7	21.6	0.086	0.090	0.093	0.094	0.081
3150	14.4	9.5	17.3	0.089	0.092	0.094	0.094	0.079
3800	12.4	6.5	14.0	0.083	0.087	0.091	0.092	0.082
4000	11.7	6.3	13.3	0.083	0.088	0.091	0.092	0.081
4500	9.4	5.4	10.8	0.078	0.081	0.084	0.084	0.073
5000	8.7	5.0	10.0	0.080	0.084	0.086	0.087	0.075

### Aluminium busbar (50 Hz, temperature=20°C)

Rated current (A)	Resistance	Reactance (10 <sup>-6</sup> Ω/m)	Impedance	Voltage drop (V/m)				
				Power factor cosφ				
				0.6	0.7	0.8	0.9	1.0
100	171.3	35.3	174.9	0.023	0.025	0.027	0.029	0.030
160	171.3	35.3	174.9	0.036	0.040	0.044	0.047	0.047
200	171.3	35.3	174.9	0.045	0.050	0.055	0.059	0.059
250	171.3	35.3	174.9	0.057	0.063	0.069	0.073	0.074
400	129.9	29.5	133.2	0.070	0.078	0.084	0.090	0.090
500	105.3	25.6	108.4	0.072	0.080	0.086	0.092	0.091
630	89.0	22.8	91.9	0.078	0.086	0.093	0.098	0.097
800	69.0	19.1	71.6	0.079	0.086	0.092	0.098	0.096
1000	59.7	17.1	62.1	0.086	0.093	0.100	0.106	0.103
1250	47.6	14.5	49.8	0.087	0.094	0.101	0.107	0.103
1350	43.0	13.6	45.1	0.086	0.093	0.100	0.105	0.101
1600	38.5	12.5	40.4	0.092	0.099	0.106	0.111	0.107
2000	31.7	10.9	33.5	0.096	0.104	0.110	0.115	0.110
2300	28.2	10.0	29.9	0.099	0.107	0.114	0.119	0.112
2500	26.3	9.5	28.0	0.101	0.109	0.116	0.121	0.114
3150	17.5	5.8	18.5	0.083	0.089	0.095	0.100	0.096
3800	14.3	5.0	15.2	0.083	0.089	0.095	0.099	0.094
4000	12.6	4.8	13.5	0.079	0.085	0.090	0.093	0.087

Notes:

- Actual voltage drop=  $V_d$  (from table)  $\times \frac{\text{actual load}}{\text{rated load}}$
- 1 feet=0.3048m  
To get the data in feet, please multiply the data with 0.3048.





[www.ge.com/ex/powerprotection](http://www.ge.com/ex/powerprotection)  
[www.ge.com/eu/powerprotection](http://www.ge.com/eu/powerprotection)

GE CONSUMER & INDUSTRIAL  
POWER PROTECTION  
Nieuwevaart 51  
B-9000 Gent - Belgium  
Tel. +32/9 265 21 11  
Fax +32/9 265 28 00  
E-mail: [gepcbel@gepc.ge.com](mailto:gepcbel@gepc.ge.com)

GE POWER CONTROLS Ltd  
129-135 Camp Road  
St Albans  
Herts AL1 5HL  
United Kingdom  
Customer Service  
Tel. 0800 587 1251  
Fax 0800 587 1239  
[gepcuk@gepc.ge.com](mailto:gepcuk@gepc.ge.com)



GE imagination at work